



# AF 350

## Exhaust grilles

Product	AF 350
Construction material	Aluminium
Finishing	Natural anodized

AF 350 exhaust grilles are used in civil and industrial facilities for conditioning, thermal-ventilation and ventilation systems.

AF 350 exhaust grilles are made as follows: With extruded anodized aluminium frame. Fixed vanes, 45° bent, pitch 30 mm. Grille AF 350 – AD 350 do not foresee the mounting of the GT 007 damper.

AF 351 grilles come with protection grid, square mesh 12.5 x 12.5 mm.

### Size

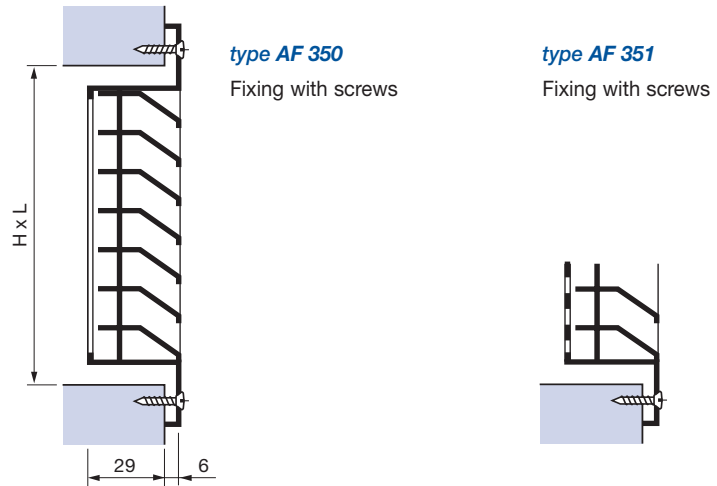

Nominal size (mm)		Nominal size (mm)	
L	H	L	H
1000	x 500	1000	x 800
1100	x 500	1100	x 800
1200	x 500	1200	x 800
1300	x 500	1300	x 800
1400	x 500	1400	x 800
1500	x 500	1500	x 800
1000	x 600	1000	x 900
1100	x 600	1100	x 900
1200	x 600	1200	x 900
1300	x 600	1300	x 900
1400	x 600	1400	x 900
1500	x 600	1500	x 900
1000	x 700	1000	x 1000
1100	x 700	1100	x 1000
1200	x 700	1200	x 1000
1300	x 700	1300	x 1000
1400	x 700	1400	x 1000
1500	x 700	1500	x 1000

# AF 350

## exhaust grilles

### Quick selection

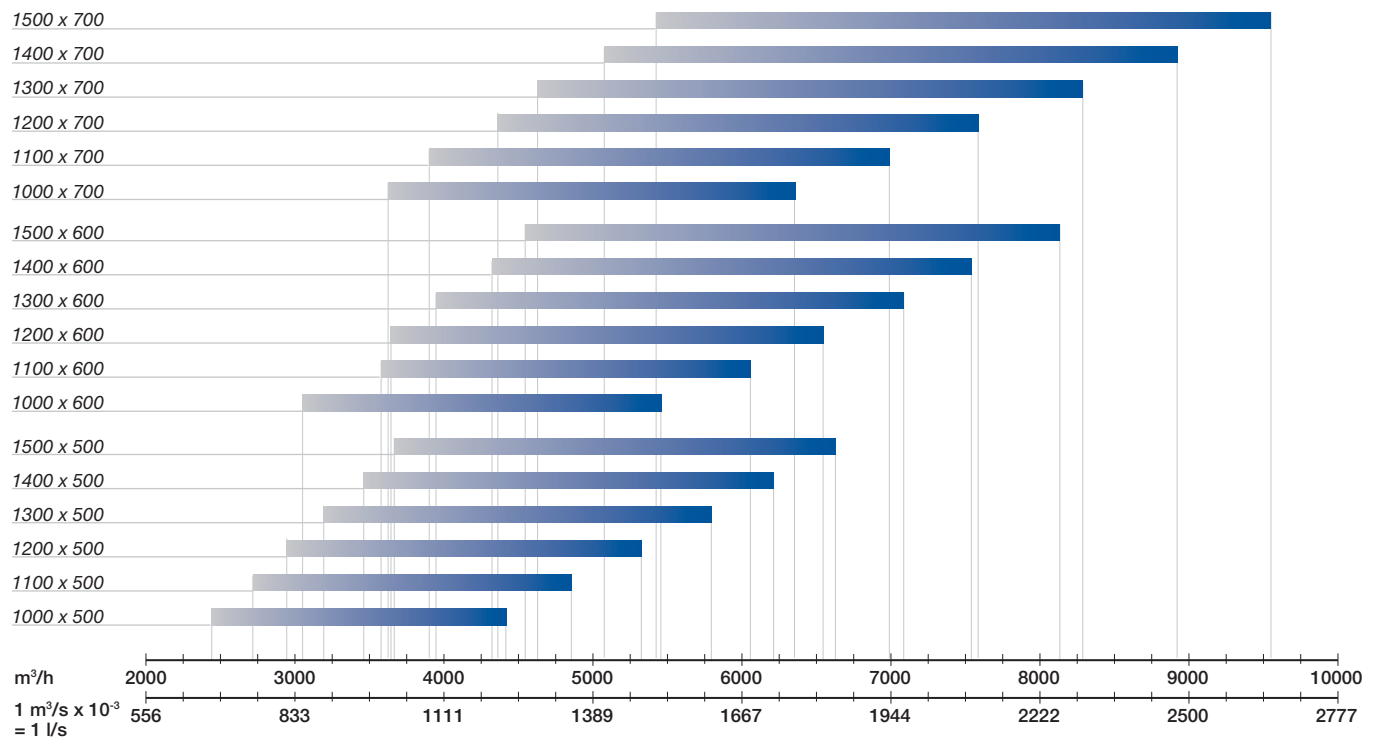
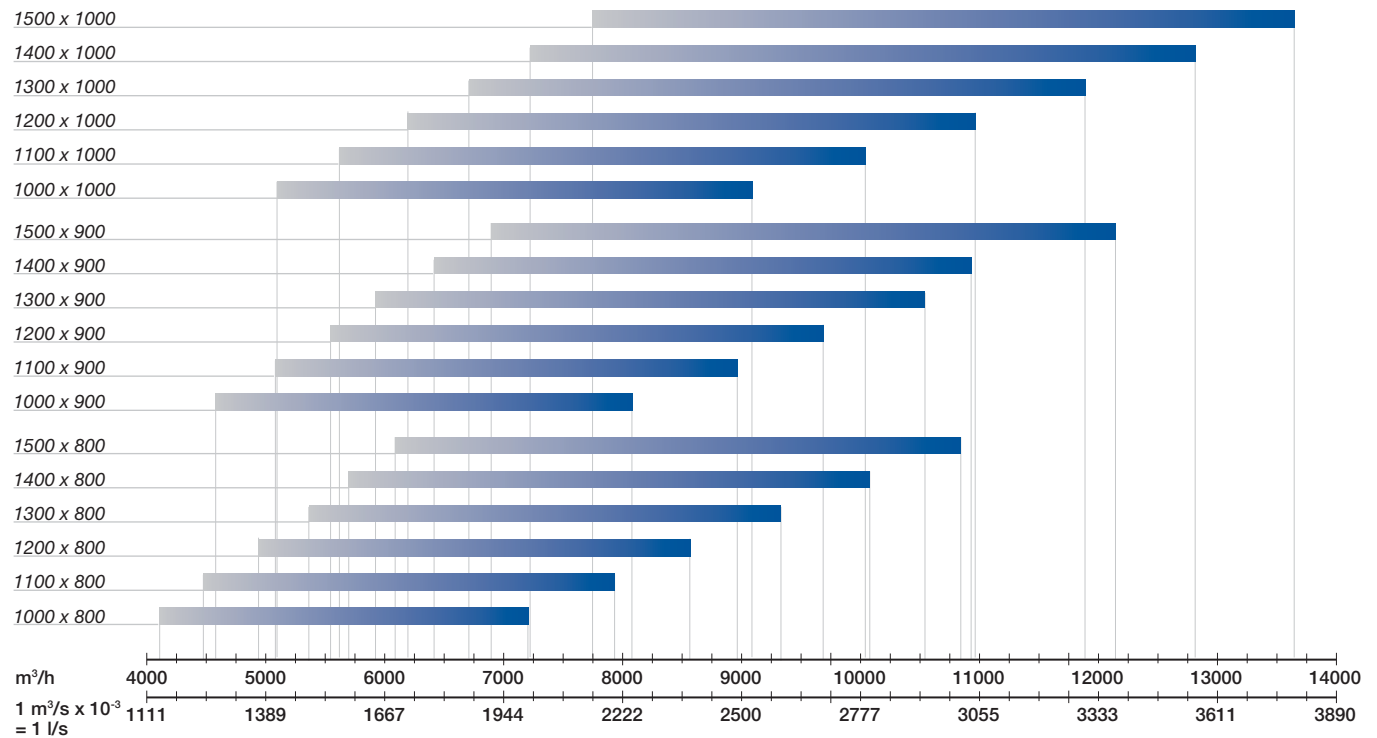

The air flow rates and the pressure drop rates are certified according to the UNI 8728 and prEN 12238 standards, by an independent and certified body, in compliance with the legislation in force on energy saving standards.

	Q min.	Q max
NR	< 25	< 35
Pressure drop Pa	< 10	< 30